

CT400

Contactless Payment Terminal

Getting Started Guide

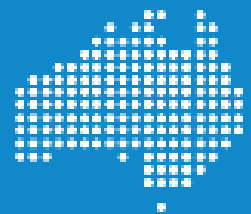

Designed & Developed in **Australia** by

QUEST
payment systems

Authorised Distributor:



Revision 1
18 May 2018

WHAT'S IN THE BOX



CT400 UNIT

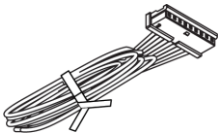

CABLE

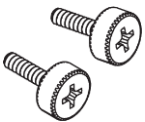

THUMBSCREW (2)



SIM CARD (size: micro)

(not always included)

(may be pre-installed inside CT400)



SIM HATCH

(may be pre-fitted to CT400)

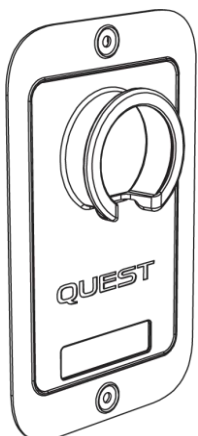

PANEL GASKET

(may be pre-fitted to CT400)

PRODUCT TOUR

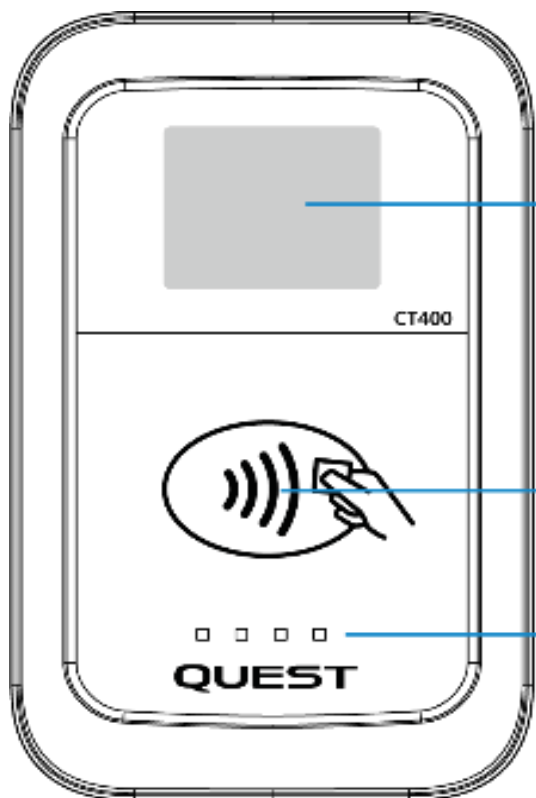

Colour Display

Contactless Tap Zone

Contactless Status Lights

FRONT VIEW

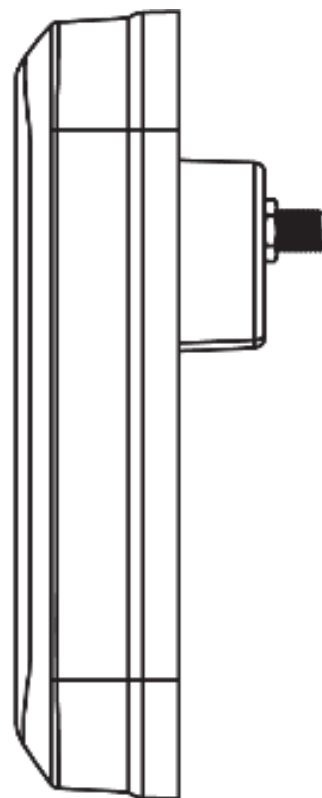

SIDE VIEW

Panel Gasket not shown

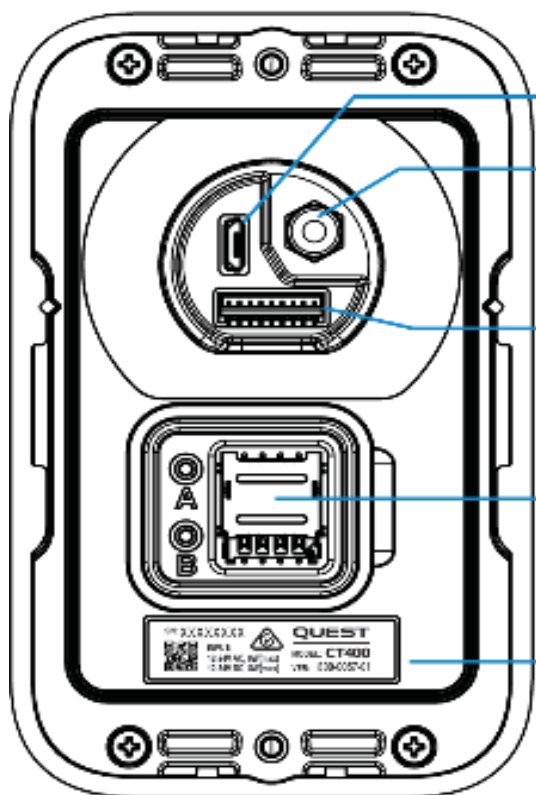

Factory Loading Port

External Cellular Antenna Connector (1/4" SMA)

Power Supply & Communications Port (to host machine)

3G SIM tray (micro)

Serial Number label

BACK VIEW

Panel Gasket & SIM Hatch not shown

FORMS OF PAYMENT ACCEPTED



INSTALLATION

1 CHECK

Ensure the machine has the correct panel cutout. Ensure the machine face is flat and free from dents, warpage and protrusions.

2 INSERT SIM CARD

(Must be completed BEFORE fitting to the machine)

- Place CT400 face down on horizontal surface.
- Lift Panel Gasket up (if fitted).
- Peel out SIM Hatch and set aside (keep free of dirt).
- Slide metal cover of SIM tray down and flip out.
- Place micro SIM card in tray with contacts facing the device (down).

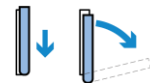
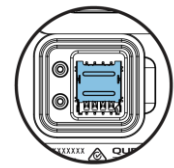

To unlock & open



Micro SIM orientation

(Contacts on back)

- To lock SIM card in place, flip back metal cover, lightly press down cover while sliding up. Cover will click into place.
- Refit SIM Hatch by pressing the corners in first, then around the perimeter. To ensure a water seal, the SIM hatch must sit flush with the back surface of CT400.
- Refit Panel gasket onto back of CT400.

3 FIT CT400 ONTO MACHINE

- Place CT400 onto face of machine. Ensure Panel Gasket is fully pulled through the large hole on the panel.
- Loosely fit both thumbscrews provided.
- Tighten thumbscrews with PH#2 screwdriver.
- Remove the clear film from the glass and discard.

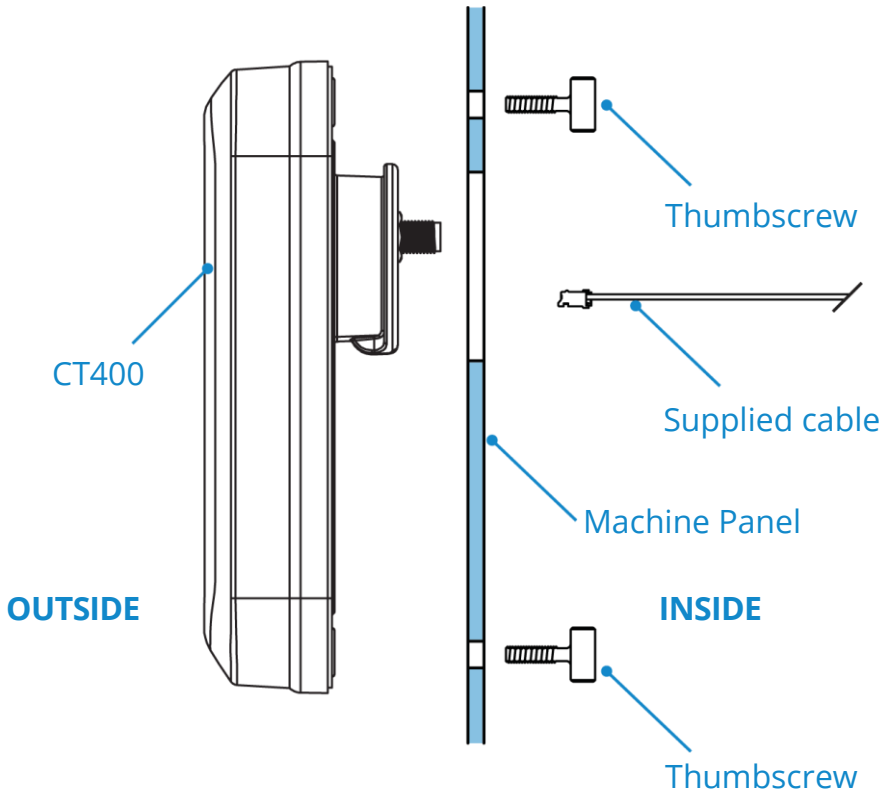

4 CONNECT

- Ensure the power to the machine is OFF.
- Connect supplied cable to the machine as per instructions by Prowash.
- Plug connector into CT400 (Note: Connector will only plug in one way. Do not force)

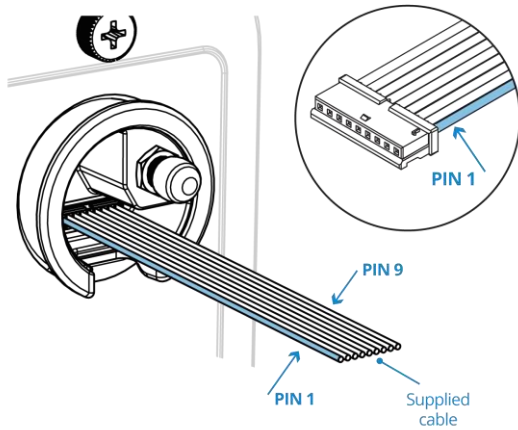

PIN #	COLOUR	DETAIL
1	YELLOW	RELAY CONTACT
2	YELLOW	RELAY CONTACT
3	ORANGE	24V AC_N
4	RED	24V AC_A
5	BLACK	RS232_RXD
6	BROWN	RS23_TXD
7	BLUE	GND
8	PURPLE	CC TALK
9	GRAY	GND

NOTE

If connecting to 12V

*+ terminal is PIN 4, **Ground** is PIN 3*

- Tether cable to machine so that the cable runs UP to CT400 (see below):

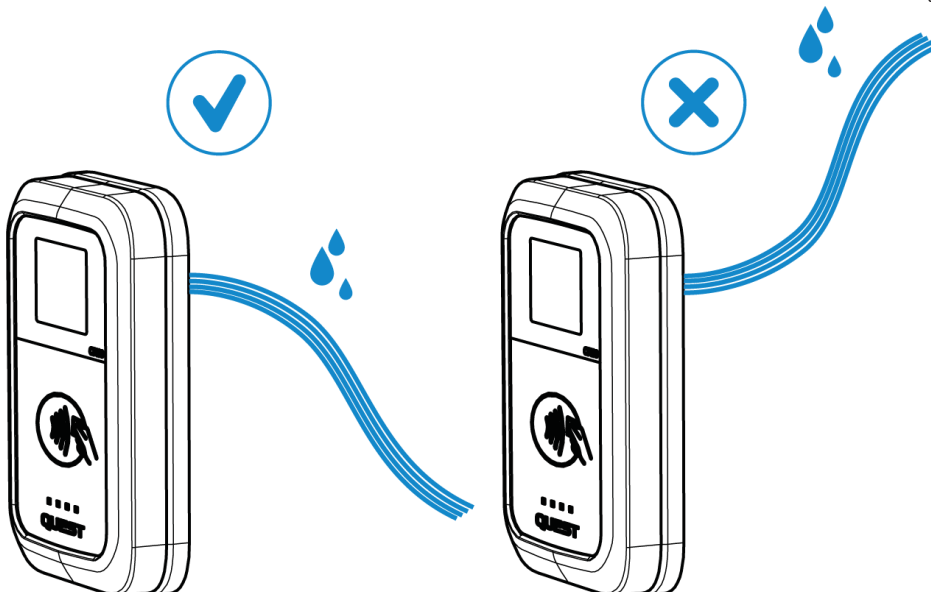

5 TEST

- Turn on power to the Machine.
- When power is applied, the CT400 will boot up.
- CT400 will connect to the Cellular network. Note: Logging onto a network may take a few minutes.
- Ensure the Cellular reception is adequate. If not, then a well-positioned external Antenna should be connected to the SMA connection on the back of CT400. Reception of one bar will require you to use an external antenna. When an external antenna is fitted, CT400 will automatically use this antenna.

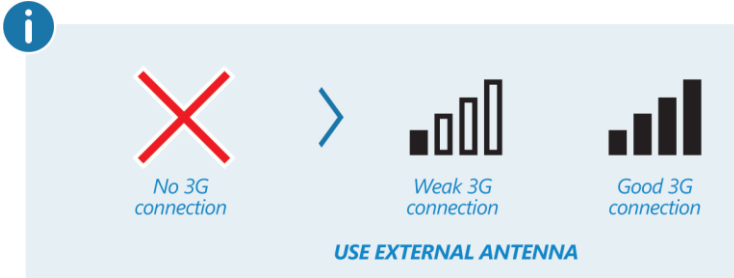

- CT400 is ready to take a payment when the Home screen is visible and the left most Status light is flashing. Using a Contactless enabled card, tap the card on CT400 to make a test purchase (all four lights will illuminate including a beep).

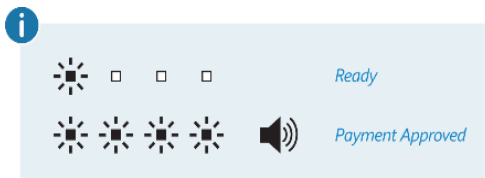

- Installation is now complete.

CONNECT EXTERNAL 3G ANTENNA (OPTIONAL)

- Remove the protective Cap from the SMA connector on the back of the CT400 unit.
- Hand tighten Co-ax cable of the external antenna onto SMA connector.
- Tighten Co-ax cable with spanner (do not over tighten).

ERROR CODES

If the device displays an error code listed below, please take the appropriate action.

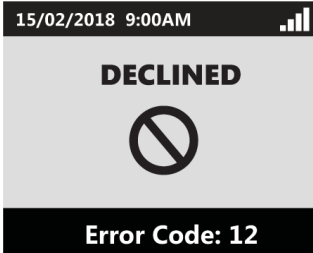

Example:

MESSAGE	POSSIBLE CAUSE	ACTION
NO CARD PAYMENT	<ul style="list-style-type: none">• Backend system is unavailable• Could not log onto Backend system• Configuration Error• Terminal may be blacklisted• SIM card is unknown• Serial number is unknown• APN not configured	<ul style="list-style-type: none">• Contact Support
NO CARD PAYMENT - CASH ONLY	<ul style="list-style-type: none">• Terminal is disabled in the Cloud system	<ul style="list-style-type: none">• Contact Support
LOGON REQUIRED	<ul style="list-style-type: none">• Terminal is disabled in the Cloud system	<ul style="list-style-type: none">• Wait until terminal logs on• If logon is not successful within 15 minutes, contact support
NO CARD PAYMENT - NO SIM CARD	<ul style="list-style-type: none">• No SIM is fitted to the terminal• SIM is faulty or damaged	<ul style="list-style-type: none">• Check SIM card is fitted and inserted the correct way up.• Check SIM card is not damaged• If above does not rectify the issue, contact support
FIRMWARE DOWNLOAD	<ul style="list-style-type: none">• An update to the terminal is required	<ul style="list-style-type: none">• Wait until Terminal finishes update and returns to idlecontact support
CARD EXPIRED	<ul style="list-style-type: none">• Card is expired or faulty	<ul style="list-style-type: none">• Merchant to advise customer to contact their bank or try another card or alternative form of payment

ONLINE PORTAL

Information on the transactions made by the CT400 device/s are available to authorised people via the online portal.



REVIEWING TRANSACTION HISTORY

- Step 1.** In a web browser, go to: mel.cloudeftrightpos.com
- 2.** 'Log on' by entering the User name & Password supplied to you by Prowash.
- 3.** On the Reporting page, click the 'Transactions' button. At this point, you'll be presented with a summary page of the transactions processed within a given period.

Use a date range to filter your results.

The following reports are available by clicking on the 'Report type' drop down box:

- Transaction Overview Report
- Detailed Transaction Report
- Detailed Card Report
- Card Summary Report

CARE

- Do not drop CT400 before installation. Rough handling could break internal circuit boards and mechanics.
- Do not expose this equipment to harsh cleaning chemicals (e.g. acids) as they may have an adverse affect on the cosmetics and structural integrity of the enclosure.
- Avoid contact with metal objects to avoid unsightly scratches.
- Store CT400 in a cool dry place. Do not place in long term storage without power for greater than 6 months. Storing for a longer time will compromise the internal payment security mechanisms.
- Do not disassemble CT400. If service or repair is required, contact Prowash to organise for the device to be returned to Quest (manufacturer). If the device is disassembled, it will void the warranty and may render the device inoperable.

LOST OR STOLEN DEVICES

If your device is stolen or is lost, please contact the Prowash team for deactivation. Acting promptly will help to reduce potential for fraud.

 **Phone:** (+61) 3 8340 3200



HARDWARE WARRANTY

Quest Payment Systems Pty Ltd (Quest) hardware products are warranted against defects caused by faulty workmanship and materials for twelve (12) months from the date of supply for new products, and ninety (90) days from the date of repair for refurbished or repaired products.

This warranty does not apply to defects caused by the hardware products not being used in accordance with instructions, accidental damage, damage caused by external forces, liquids damage, misuse, security tamper activation, fair wear and tear, or repair or attempted repair by unauthorised persons. All warranties not referred to in this document are excluded.

Subject to Quest's rights under the Australian Consumer Law (which Quest fully reserves), our goods come with guarantees that cannot be excluded under the Australian Consumer Law. You are entitled to a replacement or refund for a major failure and compensation for any other reasonably foreseeable loss or damage. You are also entitled to have the goods repaired or replaced if the goods fail to be of acceptable quality and the failure does not amount to a major failure.

You agree that our hardware products will be of acceptable quality if they remain functional in accordance with their specifications and accompanying documentation for twelve (12) months from the date of supply for new products, and ninety (90) days from the date of repair for refurbished or repaired products.

The liability of Quest for the breach of the consumer guarantees in the Australian Consumer Law and all other liability in relation to our hardware products is limited to, at the option of Quest, the repair or replacement of the hardware product, the supply of an equivalent hardware product or the payment of the costs of replacing or repairing the hardware product.

If you wish to make a claim under the warranty against defects set out above or the consumer guarantees in the Australian Consumer Law, you must return the relevant hardware product to Quest within twelve (12) months from the date of supply for new products, and ninety (90) days from the date of repair for refurbished or repaired products.

Freight and insurance charges to and from Quest are your responsibility.



PROWASH

HELP DESK

Phone: (+61) 3 8340 3200

Email: sales@prowash.com.au

Website: www.prowash.com.au

Standard hours of operation are 9.00am to 5:00pm (EST)
Monday to Friday, excluding National and Victorian public holidays.

QUEST
payment systems